

## Clamp Brackets to suit Redwall Detectors

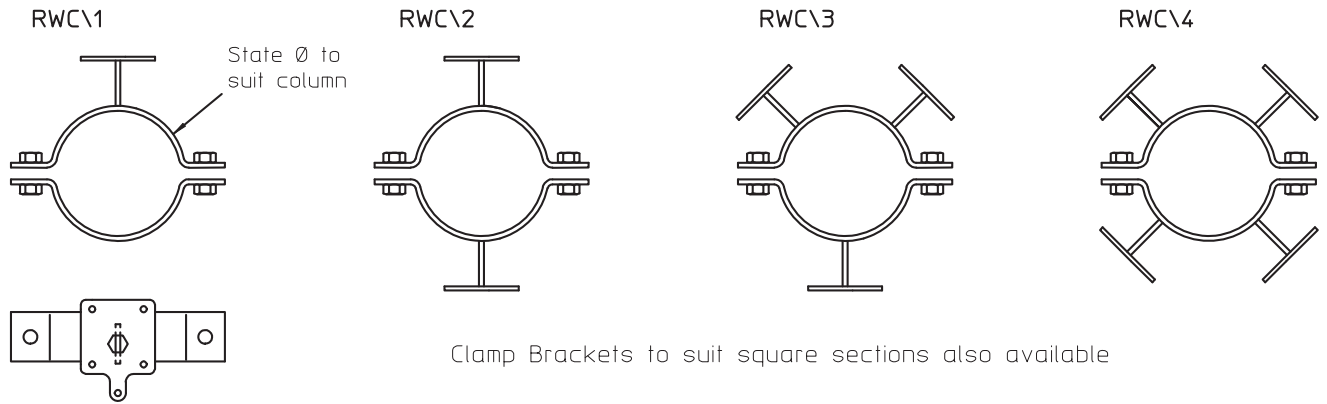

Clamp Brackets to suit square sections also available

### UPCA

Universal pole clamp adaptor

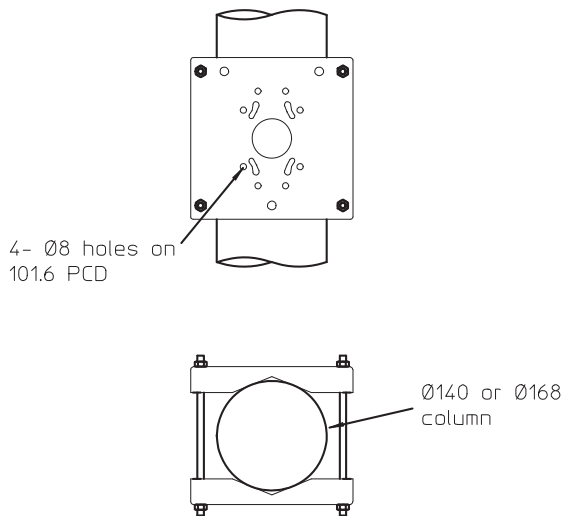

### LRC

Clamp on ladder support

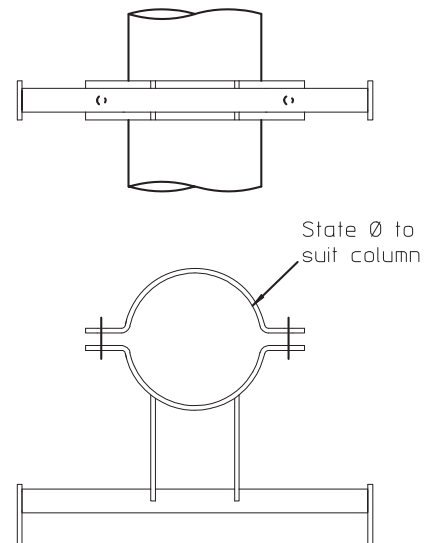

Ref.	Lg.	Notes
CS150	150	4 radial slots- 6.7 wide, equi-spaced on 101.6 PCD Ø127
CS225	225	
CS300	300	
CS450	450	
CS600	600	
CS1000	1000	
CS1500	1500	
CS2000	2000	

### Standards Applicable

#### General Steelwork:

BS 1449:1991, BS 1387:1985  
BS EN 10025:1993

#### Structural Steelwork:

BS EN 10210-1:1994  
BS EN 10210-2:1997

#### Hot Dipped Galvanized:

BS EN ISO 1461:2009

#### Welding Procedures:

Comply with BS EN 1011-2:2001

#### Fasteners:

Grade 8.8 BS 3692:2001  
BS 4190:2001 DIN931, DIN934

#### Design Wind Loading:

In accordance with CP3 chapter V Pt 2 & BS 6399 Pt 2:1997

#### Paint finishes:

BS 4800 & RAL colour range