

Technical Specification

General Specification

- Galvanized for maximum weather protection & low maintenance
- Standard pan and tilt fixings of 101.6 PCD
- Fixings included for telemetry receiver
- Built in cable entry and exit points
- Two and three metre sectional construction
- Equipment loading of up to 25kg
- Buried root or flange-mounted versions available
- Heights available from 4 to 12 metres
- Compatible with WEC adaptors and accessories

Safety Notice

It is important that all operatives are familiar with all operating instructions and procedures.

Maximum equipment load on all towers 25kg.

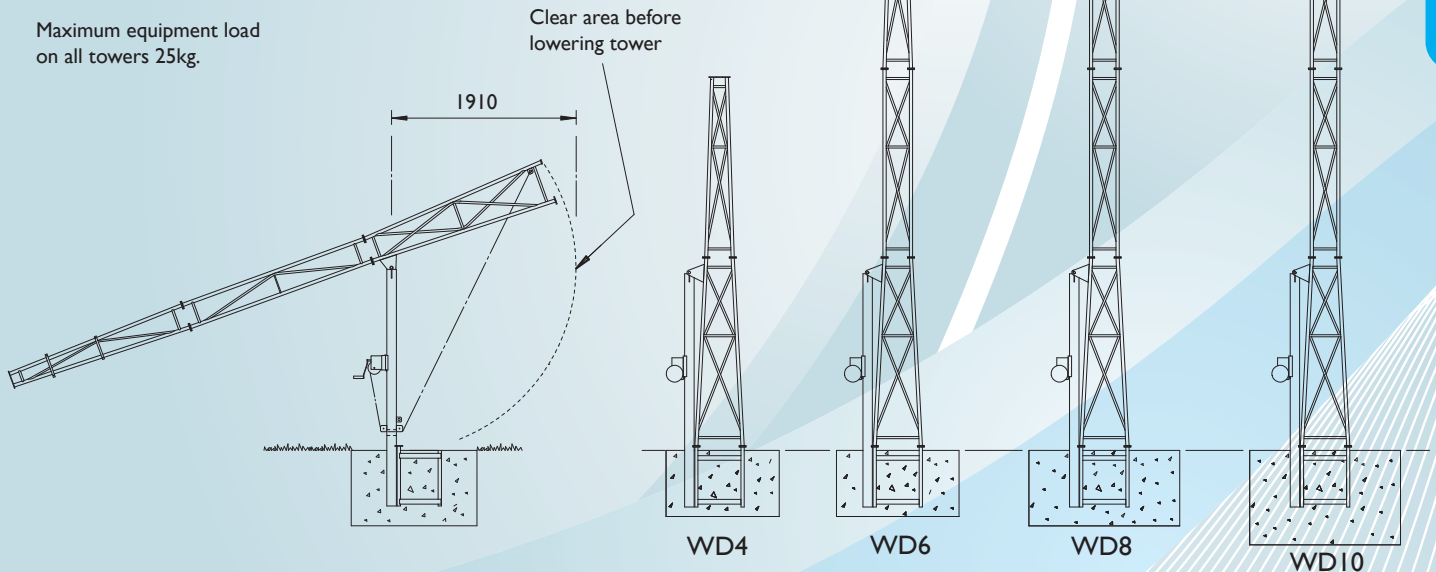

Standards Applicable

- Structural Steelwork: BS EN 10210-1:1994, BS EN 10210-2:1997
- General Steelwork: BS1449:1991, BS1387:1985, BS EN 10025:1993
- Hot Dipped Galvanized: BS EN ISO 1461:1999
- Welding Procedures: Comply with BS5135:1984
- Fasteners: Grade 8.8 BS3692:2001, BS4190:2001, DIN931, DIN934
- Design Wind Loading: In accordance with CP3 chapter V Pt 2 & BS 6399 Pt 2:1997

Transferable winch unit allows reduced cost in multi-site servicing and secure installation.

WUA - Heavy duty
WUB - Light duty

Ht.	Winch Selection	
4m	WUA	WUB
6m	WUA	WUB
8m	WUA	—
10m	WUA	—

Removable Winches

Although the WUA auto brake winch is initially more expensive, it has the versatility to cover the range of WEC products and has a quicker operating action.

Accessories & Adaptors	
Part ref.	Description
WD/ACB1	Anti Climb Bracket
WD/ACB1-M	Security mesh welded in lower section
WD/Paint	Painting in BS4800 & RAL colours
WDAF	Adaptor Flange Version
WD/SDA	Swept Dome Adaptor
WD/SDA2	Swept Dome Adaptor Dual
WD/TCA	Tower Clamp Adaptor
WD/PT1/S2	1 Pan & Tilt c/w 2 Static Adaptors
WD/TPTA	Twin Pan & Tilt Adaptor
WD/4SA	Quadruple Static Adaptor
WD/3SA	Triple Static Adaptor
WD/2SA	Twin Static Adaptor
WD/1SA	Pan & Tilt - Single fixed
WD/CS150-300	Column Spacers 150mm-300mm
WD/ARB1	Anti ram bollard (cast-in)

Product Ref & Ordering Information

WD 8 AF
 Wind down ———┐
 Tower height in metres —┘
 Adaptor flange ———┘

Base and Windload Specification

Concrete Foundation Table X x Y x Z							
Model Ref	Ht.	Area of Country			Area of Town		
		A	B	C	A	B	C
WD4	4m	1.0x1.0x 0.5m Dp.	1.0x1.0x 0.5m Dp.	1.0x1.0x 0.5m Dp.	1.0x1.0x 0.5m Dp.	1.0x1.0x 0.5m Dp.	1.0x1.0x 0.5m Dp.
WD6	6m	1.2x1.2x 0.6m Dp.	1.3x1.3x 0.65m Dp.	1.3x1.3x 0.65m Dp.	1.2x1.2x 0.6m Dp.	1.2x1.2x 0.6m Dp.	1.2x1.2x 0.6m Dp.
WD8	8m	1.3x1.3x 0.65m Dp.	1.4x1.4x 0.7m Dp.	1.4x1.4x 0.7m Dp.	1.3x1.3x 0.65m Dp.	1.4x1.4x 0.7m Dp.	1.4x1.4x 0.7m Dp.
WD10	10m	1.4x1.4x 0.7m Dp.	1.5x1.5x 0.75m Dp.	1.6x1.6x 0.8m Dp.	1.5x1.5x 0.75m Dp.	1.5x1.5x 0.75m Dp.	1.6x1.6x 0.8m Dp.

A minimum soil bearing pressure of 75 KN/m² is assumed

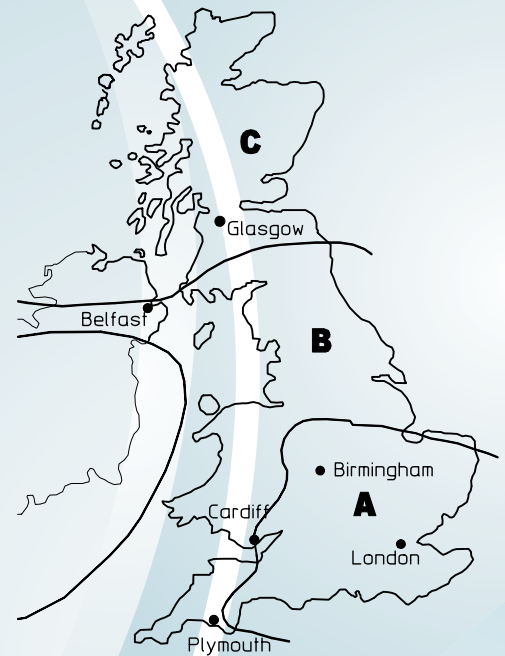

Installation Method

1. From the map, select location of installation
2. Excavate as per recommended area and depth
3. Assemble root base as shown in fig. 1
4. Place cable duct in position, if required, and firmly secure
5. Support root in the excavation using locally supplied timber or similar
6. Ensure all three mounting pads are level and protruding 45mm to 50mm above finished concrete level
7. Pour in concrete, ensuring a mix of C35 to table 6 BS 8110, tamp down and level surface
8. Check that all three pads are still level and leave to cure for a minimum of 72 hours prior to erecting the tower

Technical Support

Our in-house design facility enables us to manufacture towers to any customer specification. The technical sales department will offer expert advice on any exact requirements. Full training and instruction on the erection of towers, fixings, safe use and procedures is available on all WEC products. Project engineers, installation teams and service engineers, will all benefit from practical demonstrations, all of which can be shown on our own test site facility.

Foundation sizes are determined for three sets of wind speeds, which will cover most of the British Isles.

Area A = 44m/s (98mph)
Area B = 48m/s (107mph)
Area C = 52m/s (116mph)

Maximum gust speed is likely to be exceeded on average once every 50 years at 10m above the ground in open level country.

fig. 1

Buried Root Type (WD)

Ensure mast is perpendicular to the finished concrete level.

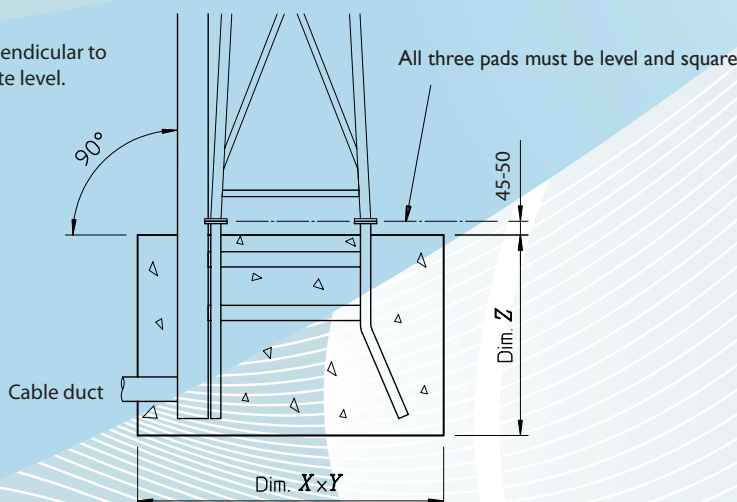

Adaptor Flange Mounted Type

